

## Ceiling mounted horizontal articulated robot

## SH35 / SH55

Gathers advanced technologies of APE company, achieving stereo hauling, selecting, inserting, arranging, gumming, assembling with high speed, high precision, high efficiency, and 360° without dead corner.

Excellent product design, high efficiency control system and convenient man-machine interaction can improve production efficiency greatly.



## Features

- Robot solution that can collect and discharge precisely.
- Small size, high speed and small installation space.
- Exclusive flexibility and universality, high price/performance ratio.
- Achieve various complex movements.
- Operation 360° without dead corner in horizontal plane.

## Industrial application

- Electronic, medical equipment, computer, aerospace aviation, commodity and automobile

## Typical application

- Material handling
- Charge/discharge material
- Spot welding
- Conveyor tracing
- Component assembly
- Visual inspection
- Measure distribution
- Shutoff device

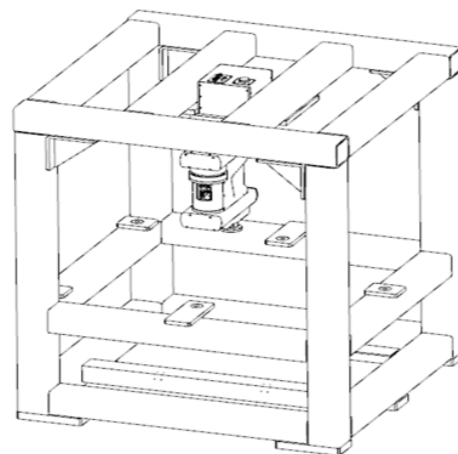

## Performance parameters

Items		SH35	SH55
Installation		Ceiling	
Configuration		Horizontal articulated robot	
Degree of freedom		4	
Drive motor		AC servo motor	
Encoder type		Absolute encoder	
Load	Rating	1Kg	1Kg
	Maximum	3Kg	4Kg
Allowable inertia torque of the fourth joint	Rating	0.005Kg.m <sup>2</sup>	0.005Kg.m <sup>2</sup>
	Maximum	0.05Kg.m <sup>2</sup>	0.05Kg.m <sup>2</sup>
Max. down force of J3		150N	
Power of each motion axis	Joint #1	400W	400W
	Joint #2	200W	400W
	Joint #3	200W	200W
	Joint #4	100W	100W
Arm length	Big arm	175mm	275mm
	Second arm	175mm	275mm
Max. radius		350mm	550mm
Working space	Joint #1	±225°	±225°
	Joint #2	±225°	±225°
	Joint #3	0 ~ 130mm	0 ~ 130mm
	Joint #4	±720°	±720°
Max. speed	Joint #1+Joint #2	6m/s	7.2m/s
	Joint #3	1.1m/s	1.1m/s
	Joint #4	2500 deg/s	1875 deg/s
	Standard cycle time (*1)	0.55s	0.5s
Repeatability positioning accuracy	Joint #1+Joint #2	±0.01mm	±0.015mm
	Joint #3	±0.01mm	±0.01mm
	Joint #4	±0.01°	±0.01°
Body weight (without cables)		21.5Kg	24.5Kg
Subscriber circuit		15 Pin D-sub	
Subscriber gas circuit		φ4mmx1 , φ6mmx2	
Environmental specification		IP20	

(\*1): Operation time is the fastest time of back and forth in horizontal 300mm, vertical 25mm during load rating.

## Size of work space (SH35)

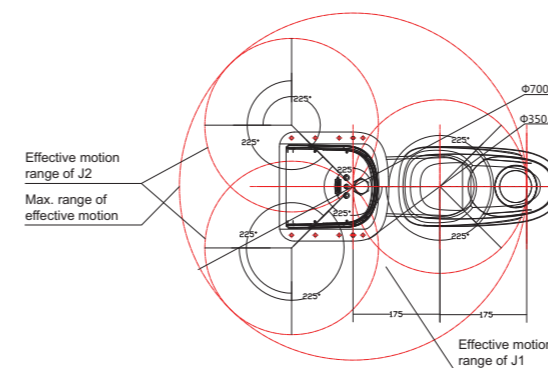

## Size of work space (SH55)

